



**Electrolux**  
PROFESSIONAL

**Cooking Range Line thermaline 90**  
**Freestanding electric pastacooker,**  
**1/1GN, 1 side, H=250 - Marine USPHS**  
**only M2M**

ITEM # \_\_\_\_\_

MODEL # \_\_\_\_\_

NAME # \_\_\_\_\_

SIS # \_\_\_\_\_

AIA # \_\_\_\_\_



589923 (HCBDBBDODM)

Electric Pasta Cooker, one-side operated with splashback, 1/1 GN - Marine USPHS (only M2M)

### Short Form Specification

**Item No.** \_\_\_\_\_

Unit constructed according to DIN 18860\_2 with 20 mm drop nose top and 120 mm recessed plinth. Internal frame for heavy duty sturdiness in stainless steel. 3mm top with 3 mm reinforcement in 1.4301 (AISI 304). Multi-purpose cooking appliance combining bain marie and pasta cooker functions. Water basin in 1.4435 (AISI 316L) stainless steel, seamlessly welded into the top of the appliance. Manual water level re-fill and water temperature regulated by sensors. Safety systems and automatic low-water level shut-off protect against overheating. All-round basin raised edges to protect against soil infiltration. Standby function saves energy and quickly recovers maximum power. Metal knobs and handles with embedded hygienic "soft-touch" grip enable easier handling and cleaning. IPX6 water resistance certification. Configuration: one side operated. Can be installed on any base, also from other supplier. Bases must be designed according to the TL90 and TL85 construction guidelines.

### Main Features

- Overheat protection: the temperature sensor switches off the supply in case of overheating.
- Automatic low-water level shut-off: no accidental over-heating.
- Filling water level is plate-marked on the side of the well.
- Easy to clean basin with rounded corners.
- Metal knobs with embedded hygienic "soft-touch" grip for easier handling and cleaning. The special design of the controls prevents infiltration of liquids or soil into vital components.
- Raised edge all around the well to protect from infiltration of dirt from worktop.
- Water temperature controlled by electronic sensor and can be selected as either temperature or power levels.
- Multi purpose cooking appliance that combines functions of bain marie and pasta cooker, allowing also the re-generation of food thanks to the electronic temperature control.
- Safety systems protect against overtemperature and can be manually reset.
- Manual water fill regulated by a water tap.
- IPX6 water protection.

### Construction

- Water basin in 1.4435 (AISI 316L) stainless steel is seamlessly welded into the top of the appliance.
- Internal frame for heavy duty sturdiness in stainless steel.
- 3mm top with 3 mm reinforcement in 1.4301 (AISI 304).

### Sustainability

- Standby function for energy saving and fast recovery of maximum power.

### Optional Accessories

- 2 half size baskets for aquacooker 1/1 GN PNC 913037
- Support frame for 6 round baskets PNC 913133
- Lid for aquacooker 1/1 GN and bain marie 1/1 GN PNC 913139
- False bottom for Aquacooker 1/1GN PNC 913680
- Portioning shelf 1000x65mm - Marine USPHS (only M2M) PNC 913713
- 6 round baskets for 40-lt pasta cookers (927219 must be ordered together) PNC 927213

**APPROVAL:** \_\_\_\_\_



Experience the Excellence  
[www.electroluxprofessional.com](http://www.electroluxprofessional.com)

Front

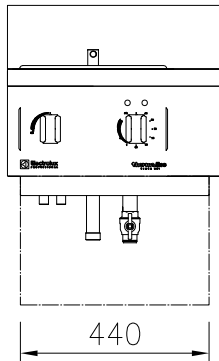

Side

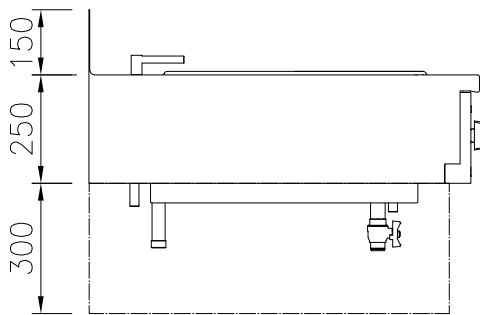

- D = Drain
- EI = Electrical inlet (power)
- EQ = Equipotential screw
- WI = Water inlet

Top

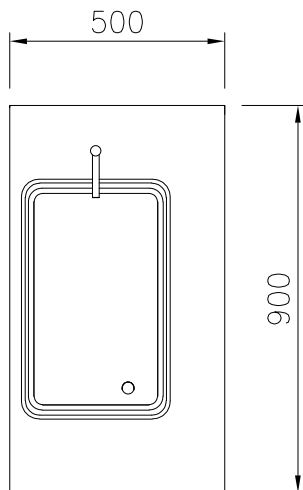
**Electric**

Supply voltage: 440 V/3 ph/60 Hz  
 Total Watts: 7.5 kW

**Water:**

Incoming Cold/hot Water line size: 3/4"  
 Drain line size: 1"

**Key Information:**

Number of wells: 1  
 Usable well dimensions (width): 309 mm  
 Usable well dimensions (height): 205 mm  
 Usable well dimensions (depth): 512 mm  
 Well capacity: 5 lt MIN; 21 lt MAX  
 Thermostat Range: 40 °C MIN; 90 °C MAX  
 External dimensions, Width: 500 mm  
 External dimensions, Depth: 900 mm  
 External dimensions, Height: 250 mm  
 Net weight: 45 kg  
 Configuration: One-Side Operated;Top

**Sustainability**

Current consumption: 9.9 Amps